

1. ALL DIMENSIONS ARE IN FEET AND INCHES.
 2. DIMENSIONS ARE TO FACE UNLESS NOTED OTHERWISE.
 3. DIMENSIONS ARE TO CENTERLINE UNLESS NOTED OTHERWISE.
 4. DIMENSIONS ARE TO CENTERLINE UNLESS NOTED OTHERWISE.

NO.	DESCRIPTION	DATE
1	ISSUED FOR PERMIT	08/11/2011
2	ISSUED FOR PERMIT	08/11/2011
3	ISSUED FOR PERMIT	08/11/2011
4	ISSUED FOR PERMIT	08/11/2011

NO.	DESCRIPTION	DATE
1	ISSUED FOR PERMIT	08/11/2011
2	ISSUED FOR PERMIT	08/11/2011
3	ISSUED FOR PERMIT	08/11/2011
4	ISSUED FOR PERMIT	08/11/2011

NO.	DESCRIPTION	DATE
1	ISSUED FOR PERMIT	08/11/2011
2	ISSUED FOR PERMIT	08/11/2011
3	ISSUED FOR PERMIT	08/11/2011
4	ISSUED FOR PERMIT	08/11/2011

TITLE: **2 Section IPC**
 SHEET NO.: **C**
 SCALE: 1/32"=1'-0"
 SHEET 1 OF 1

NO.	DESCRIPTION	DATE
1	ISSUED FOR PERMIT	08/11/2011
2	ISSUED FOR PERMIT	08/11/2011
3	ISSUED FOR PERMIT	08/11/2011
4	ISSUED FOR PERMIT	08/11/2011

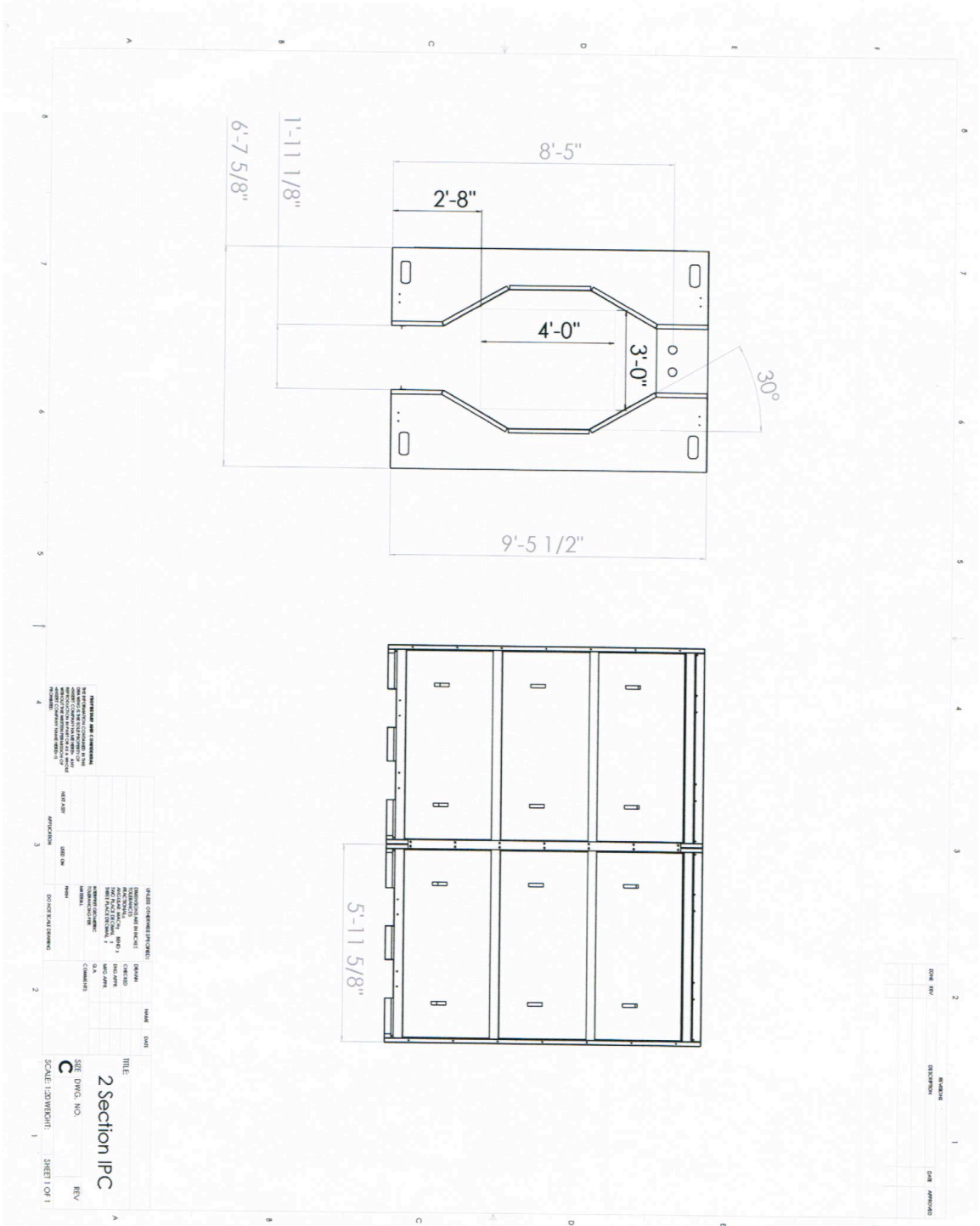

NO.	DATE	BY	DESCRIPTION

NO.	DATE	BY	DESCRIPTION

NO.	DATE	BY	DESCRIPTION

TITLE: **2 Section IPC**
 DATE: 01/11/2011
 SCALE: 1/8" = 1'-0"
 SHEET 1 OF 1

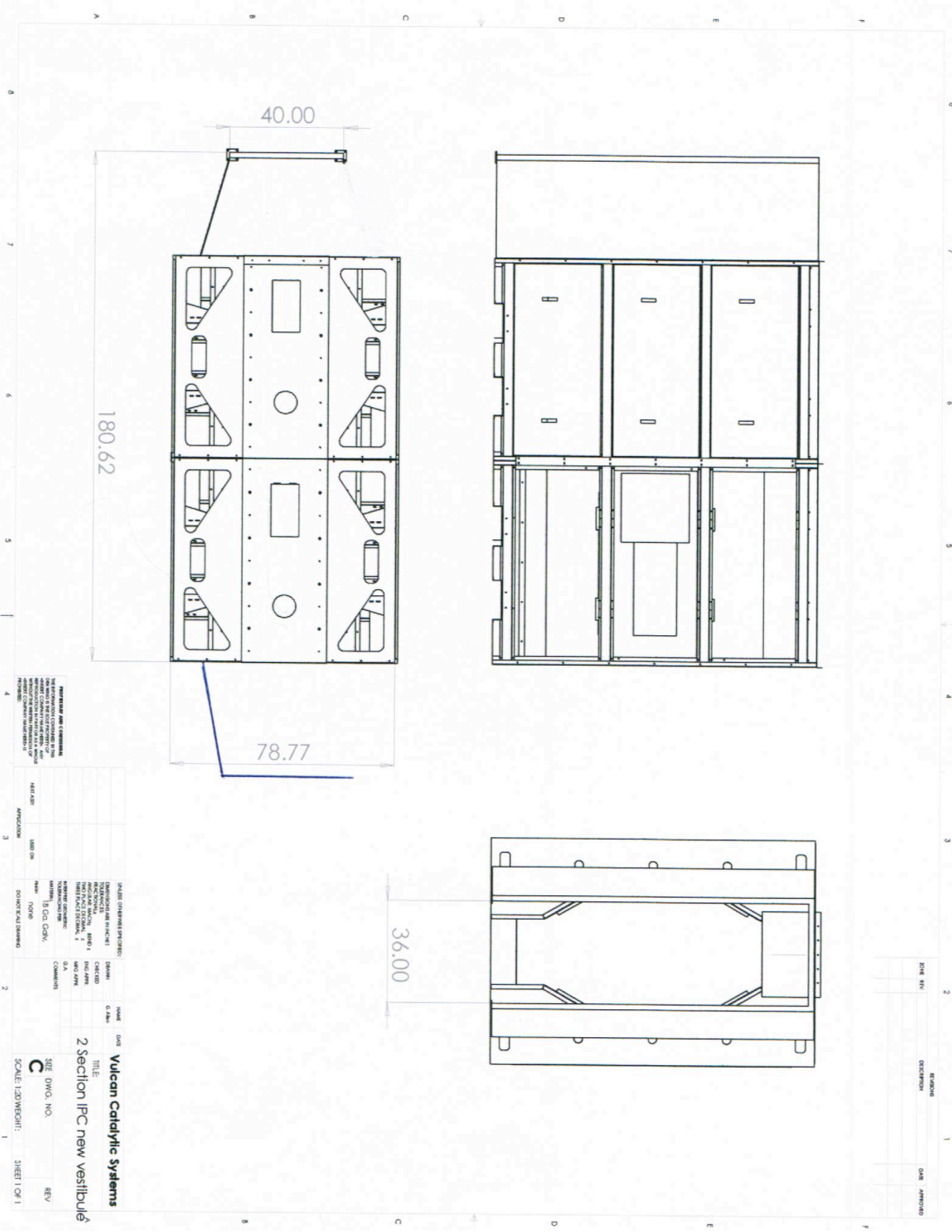

1. 2. 3. 4. 5. 6. 7. 8. 9. 10. 11. 12. 13. 14. 15. 16. 17. 18. 19. 20. 21. 22. 23. 24. 25. 26. 27. 28. 29. 30. 31. 32. 33. 34. 35. 36. 37. 38. 39. 40. 41. 42. 43. 44. 45. 46. 47. 48. 49. 50. 51. 52. 53. 54. 55. 56. 57. 58. 59. 60. 61. 62. 63. 64. 65. 66. 67. 68. 69. 70. 71. 72. 73. 74. 75. 76. 77. 78. 79. 80. 81. 82. 83. 84. 85. 86. 87. 88. 89. 90. 91. 92. 93. 94. 95. 96. 97. 98. 99. 100.

| NO. | DESCRIPTION | DATE | BY | CHKD. |
|-----|-------------------------|------|----|-------|
| 1 | ISSUED FOR PERMITS | | | |
| 2 | ISSUED FOR CONSTRUCTION | | | |
| 3 | ISSUED FOR RECORD | | | |

| | |
|----------|-------------|
| PROJECT: | 18 CGI, GYM |
| CLIENT: | 18 CGI, GYM |
| DATE: | 18 CGI, GYM |
| SCALE: | 1:20 |
| DATE: | 18 CGI, GYM |
| SCALE: | 1:20 |

Vulcan Catalytic Systems
 TITLE: 2 Section IPC new vestibule
 SHEET NO. C
 SCALE: 1/20
 SHEET 1 OF 1

| ZONE | REV | DESCRIPTION | DATE | APPROVAL |
|------|-----|-------------|------|----------|
| | | | | |
| | | | | |
| | | | | |

Part Flow →

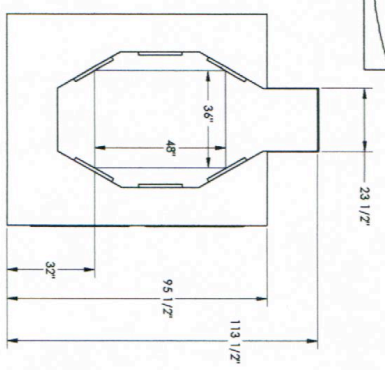
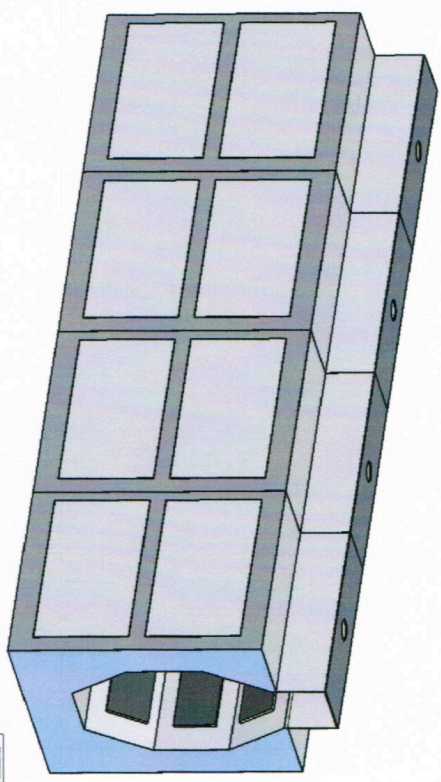
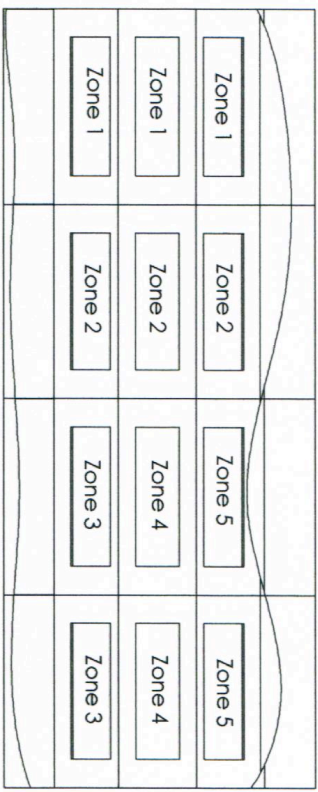

REVISIONS AND COMMENTS
 REVISION NO. DATE DESCRIPTION
 1 11/11/11 11/11/11

| NO. | DATE | DESCRIPTION |
|-----|------|-------------|
| | | |
| | | |
| | | |

Vulcan Catalytic Systems
IPC Assembly-Zone
 SCALE: DIMENSIONS: 1:1
 SHEET NO. 1
 SHEET OF 1